



4-Way Longitudinal Sway Brace Attachment

907

Technical Features

- **Sizes available for bracing pipe (Nominal) :** DN25 x DN25 / 1" x 1", DN25 x DN32 / 1" x 1 1/4" and DN32 x DN32 / 1 1/4" x 1 1/4".
- **Features :** Universal swivel design makes it possible to achieve any angle of attachment. Bracing pipe end requires no threads.
- **Material :** Carbon steel, with hardened cone point engaging screw.
- **Finish :** Electrogalvanized

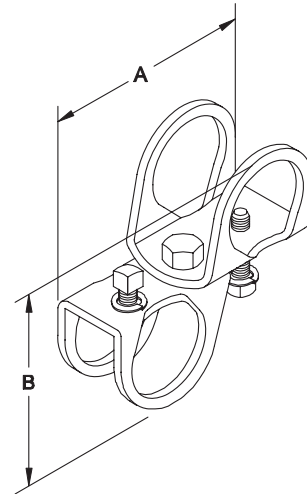

1 - When used with other Tolco® bracing products.

4-Way Longitudinal Sway Brace Attachment - 907

Physical Data

Nominal Bracing (metric)	Pipe Size (inch)	Dimensions (mm / inch)		Max. Horizontal Design Load (kg / lbs)	Box Quantity	Box Weight (kg / lbs)	Reference	
		A	B				Europe	Asia / America
DN25 x DN25	1" x 1"	121 / 4.8	111 / 4.4	297 / 655	50	22 / 48	907100100	907-0100
DN32 x DN25	1 1/4" x 1"	129 / 5.1	123 / 4.8	297 / 655	50	25 / 54	907125100	907-01250100
DN32 x DN32	1 1/4" x 1 1/4"	137 / 5.4	133 / 5.3	297 / 655	50	26 / 58	907125125	907-0125

Installation Instructions

Designed, tested, and approved to be used only with other Tolco® bracing products available from Viking SupplyNet®.

The 4-way longitudinal sway brace is used to brace pipe against sway and seismic disturbances. The attachment fitting functions as a longitudinal brace connection when attached to lateral brace pipe. When used in conjunction with Series 1000 Fast Clamp® sway brace attachment, the combination bracing restricts piping movement in tension and compression both laterally and longitudinally. The maximum horizontal design load of 297 kg (655 lbs) will accommodate up to DN100/4" pipe at maximum spacing.

The bracing connection must be positioned as close as possible to the braced pipe and not more than 76.2mm (3") away from the braced pipe. Slide bracing pipe through

the 4-way longitudinal sway brace attachment fitting. Tighten the cone point engaging screws until they bottom out against the attachment fitting.

Length of bracing pipe per the National Fire Protection Association (NFPA) 13, 1999 Edition, Table 6-4.5.8. (L/R=200): 1" schedule 40 pipe maximum 7'-0"; 1 1/4" schedule 40 pipe maximum 9'-0".

Alternative pipe materials are currently under review.

